



WANTAI MOTOR

We are professional stepper motor (stepping motor) supplier and Manufacturer

- 中文版
- English
- Deutsch
- Русский язык

[HomePage](#)

[AboutUs](#)

[News](#)

[Products](#)

[Technic](#)

[GuestBook](#)

[ContactUs](#)

Hybrid Stepping Motor Products

Products

- Hybrid Stepping Motor
- Hybrid Stepping Gearmotor
- Stepper Motor Driver
- Brushless DC Motor
- Brushless DC Motor Driver
- CNC Router kits
- PM Stepping Motor
- Power Supply

AgentProduct

- Technic

Keyword:

Category:

[SEARCH](#)

[RESET](#)

Tel: 0086-519-85138377
0086-519-85190539
Fax: 0086-519-85139178

E-mail: sales@wantmotor.com
mike@wantmotor.com
ada@wantmotor.com
anna@wantmotor.com
michelle@wantmotor.com



Hybrid Stepping Motor 42BYGH

Product No.: N2007824165718

General Specifications

Step Accuracy-----+5%
Temperature Rise-----80°C Max
Ambient Temperature Range----- -20°~+50°
Insulation Resistance----- 100MΩ Min 500VDC
Dielectric Strength----- 500VAC 1 Minute



Electrical Specifications



Model	Step Angle (°)	Motor Length (mm)	Rated Voltage (V)	Rated Current (A)	Phase Resistance (Ω)	Phase Inductance (mH)	Holding Torque (g.cm)	Lead Wires (NO.)	Rotor Inertia (g.cm ²)	Detent Torque (g.cm)	Motor Weight (kg)
42BYGH201	1.8	34	12	0.16	75	42	950	5	34	200	0.2
42BYGH202	1.8	34	12	0.3	40	22	1250	6	34	200	0.2

42BYG H610	1.8	40	6.5	1.2	6	13	3000	4	54	220	0.24
42BYG H613	1.8	40	2.4	1.7	1.5	2.5	3500	4	54	220	0.24
42BYG H616	1.8	40	4.1	0.5	8	15	2600	4	54	220	0.24
42BYG H718	1.8	44	8.9	0.5	18	23	2900	6	50	250	0.3
42BYG H721	1.8	44	10	0.25	40	36	2000	6	50	250	0.3
42BYG H801	1.8	48	12	0.4	30	28	3800	6	68	280	0.34
42BYG H803	1.8	48	5.6	0.8	7	4	2600	6	68	280	0.34

Mechanical Dimensions(外型图)

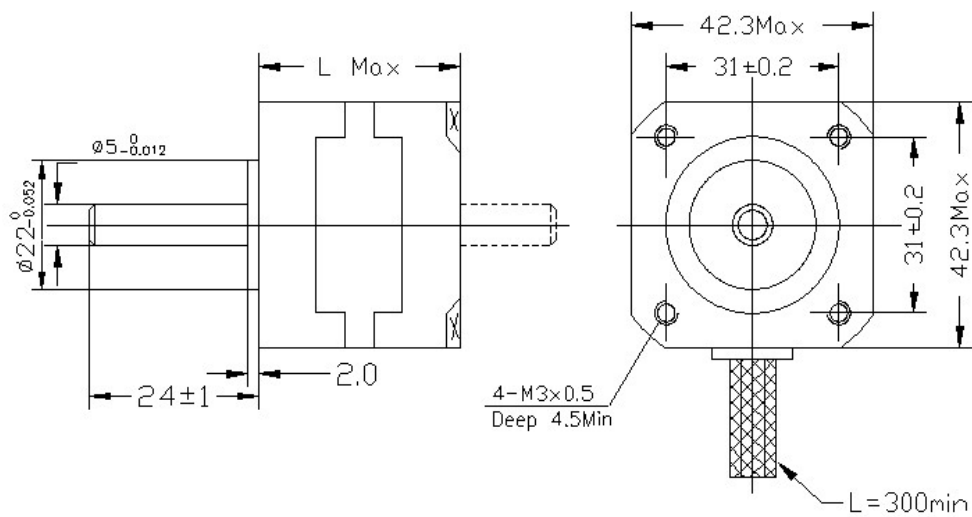

Wiring diagram (接线图):

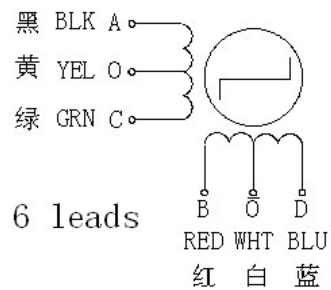
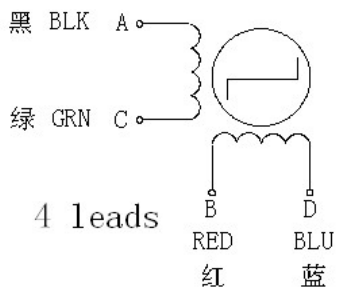

Pulse-torque Characteristics

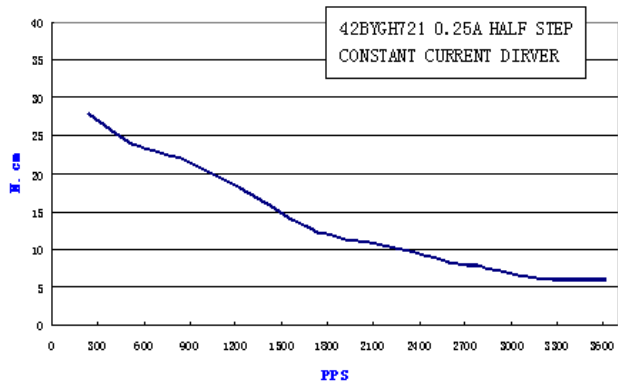
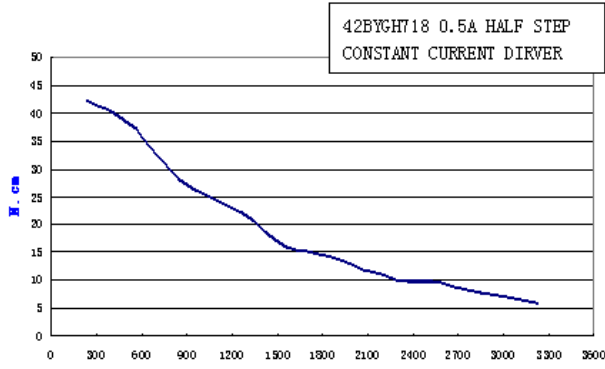
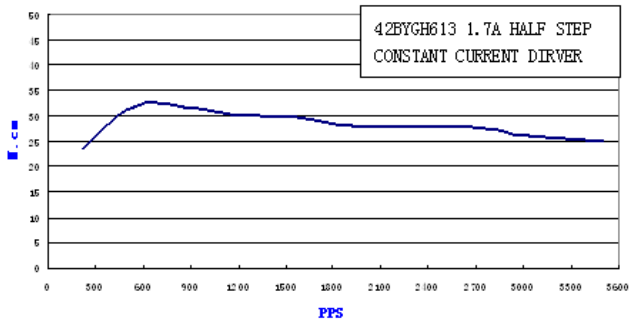
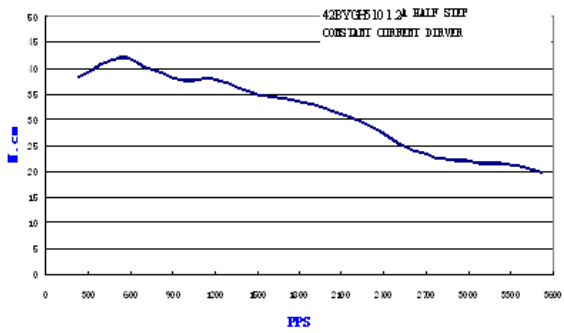
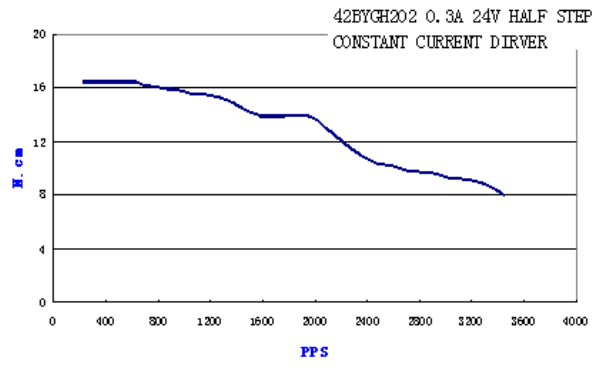

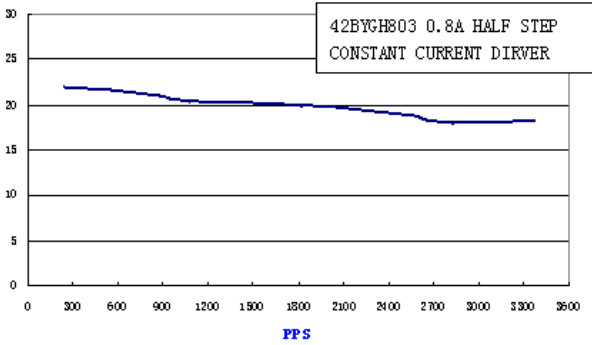
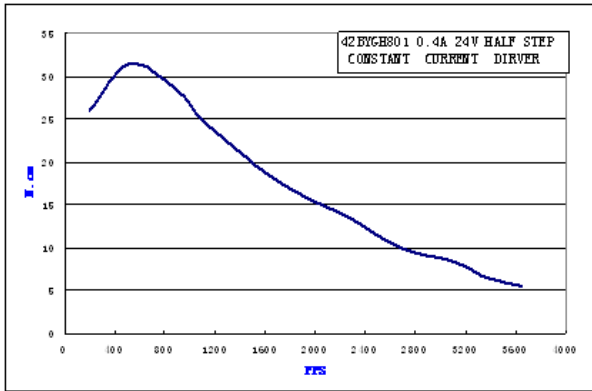

stepper motor / stepping motor / step motor / cnc router / motor control / stepper motor driver

Changzhou WanTai Electrical Appliance Co.,Ltd. Copyright All Rights Reserved. ICP07508477
provide High quality stepper motor,stepping gearmotor wholesale,stepping motor supplier